

# MarinAire®

*The Comfort You Deserve*



***"This is what a quality marine air conditioner should look like!"***

Don't settle for anything less than these standard **MarinAire®** features:

- ✓ Temperature and humidity sensed either by sensor on unit, or by remote sensor on 30' cable. [See video](#)
- ✓ Display can be set to control temperature *or* humidity for perfect cabin comfort when on board.
- ✓ Dehumidification mode available for when boat is unattended - Keeps humidity at level pre-set by operator.
- ✓ Insulated, 316 stainless steel condensate pan with 3 drains - Rugged, durable, and won't drip on to woodwork.
- ✓ Insulated, high static blower gives strong, quiet air flow, even with excessive duct back pressure.
- ✓ Blower rotates 360° (90° on 6K) - Ducting can exit right, left, top, or anywhere between.
- ✓ Three-winding blower - Eliminates annoying hum heard from electronic fan speed controls.
- ✓ High efficiency Toshiba compressor uses efficient and environmentally friendly R410a refrigerant.
- ✓ Compressor sound shield cuts compressor noise down to a whisper - Less than 44dB(A) for the two largest units.
- ✓ High and low pressure refrigerant pressure gauges - Check up on your system anytime!
- ✓ High and low pressure switches standard, for complete system protection and user safety.
- ✓ Four-row air coil with and hydrophilic coating - Better cooling and dehumidification plus corrosion protection.
- ✓ Sensor on air coil protects against icing in cool mode and overheating in heat mode.
- ✓ Cupro-Nickel water coil for excellent heat exchange and corrosion protection.
- ✓ Removeable lifting ring to aid installation and minimize damage and injury.
- ✓ Remote stainless steel electrical box on 30" umbilical cord.
- ✓ Very low start-up and running current - 16,000 Btu starts easily on a Honda 2000i generator! [See video](#)
- ✓ Attractive digital display with Vimar Idea bezel. Shows both cabin temperature *and* humidity. [See video](#)
- ✓ Wireless remote with LCD screen included. Features a timer to allow delayed turn off or turn on.
- ✓ WiFi adapter available. Enables remote control via smart-phones. (Requires WiFi and internet connection).



Coastal Climate Control, Inc.

See over for specifications

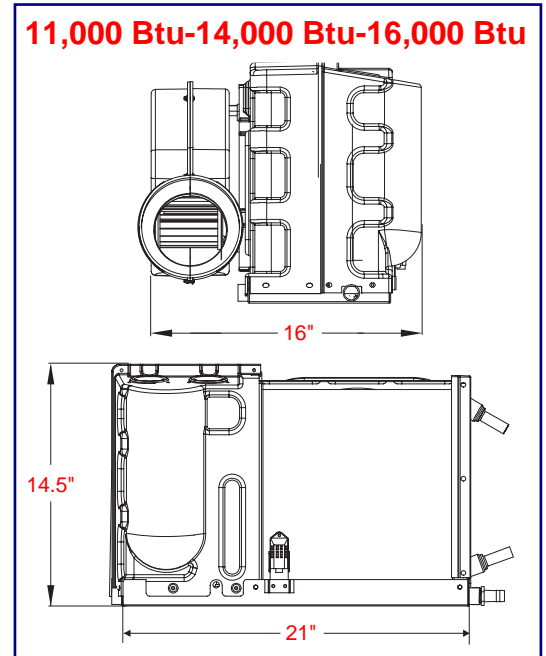
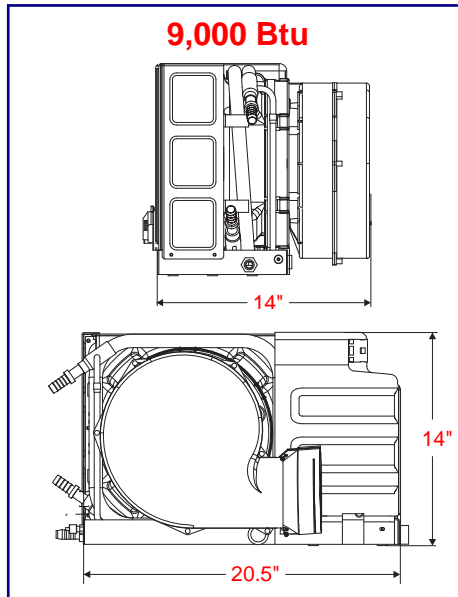
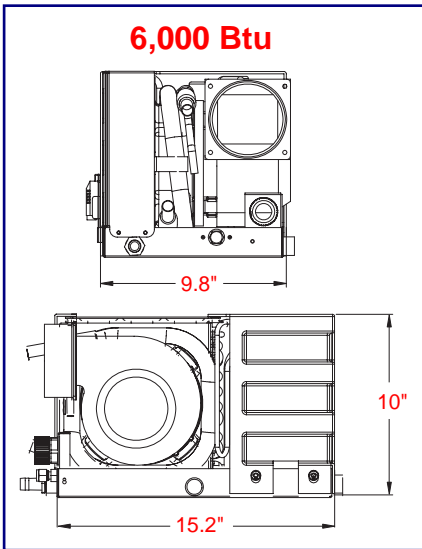

NOTE: Base Pan dimensions do not include drain fittings or service valve.

<u>Model</u>	<b>MSBA6K2</b>	<b>MSBA9K2</b>	<b>MSBA11K2</b>	<b>MSBA14K2</b>	<b>MSBA16K2</b>
<b><u>Nominal Btu Capacity (ABYC)</u></b>					
Cooling	6,000 Btu	9,000 Btu	11,000 Btu	14,000 Btu	16,000 Btu
Heating	7,000 Btu	10,000 Btu	12,000 Btu	15,000 Btu	17,000 Btu
<b><u>Cooling Capability</u></b>					
Below Decks - Night Cabin	500 cu ft	750 cu ft	900 cu ft	1,150 cu ft	1,350 cu ft
Below Decks - Day Cabin	450 cu ft	650 cu ft	785 cu ft	1,000 cu ft	1,150 cu ft
High Glass Area - i.e. salon	350 cu ft	550 cu ft	650 cu ft	850 cu ft	950 cu ft
Raised Area - Abundant Glass	300 cu ft	450 cu ft	550 cu ft	700 cu ft	800 cu ft
<b><u>Minimum Grille Area</u></b>					
Non-closeable discharge	45 sq in	60 sq in	60 sq in	70 sq in	70 sq in
Return air	90 sq in	100 sq in	120 sq in	140 sq in	140 sq in
Duct Ring diameter	4"	6"	6"	6"	6"
Minimum Water Flow	150 gph	225 gph	275 gph	350 gph	400 gph
Recommended pump - March	P250	P250	P500	P500	P500
Inlet and outlet hose size	1/2" ID	5/8" ID	5/8" ID	5/8" ID	5/8" ID
Condensate Drain hose size	5/8" ID	5/8" ID	5/8" ID	5/8" ID	5/8" ID
Power Supply	110-120v 60Hz	110-120v 60Hz	110-120v 60Hz	110-120v 60Hz	110-120v 60Hz
Running Current	6 amps	7.5 amps	8 amps	10 amps	11 amps
Minimum Wire Size	14 AWG	14 AWG	12 AWG	12 AWG	12 AWG
Maximum Breaker Size	15 amp	20 amp	20 amp	25 amp	25 amp
Noise Level	<40 dB(A)	<42dB(A)	<42dB(A)	<44dB(A)	<44dB(A)
Weight	38.5 lbs	51 lbs	61 lbs	65 lbs	67 lbs

