

# Instructions for adding an Air Condenser to a Frigoboat Keel Cooled system

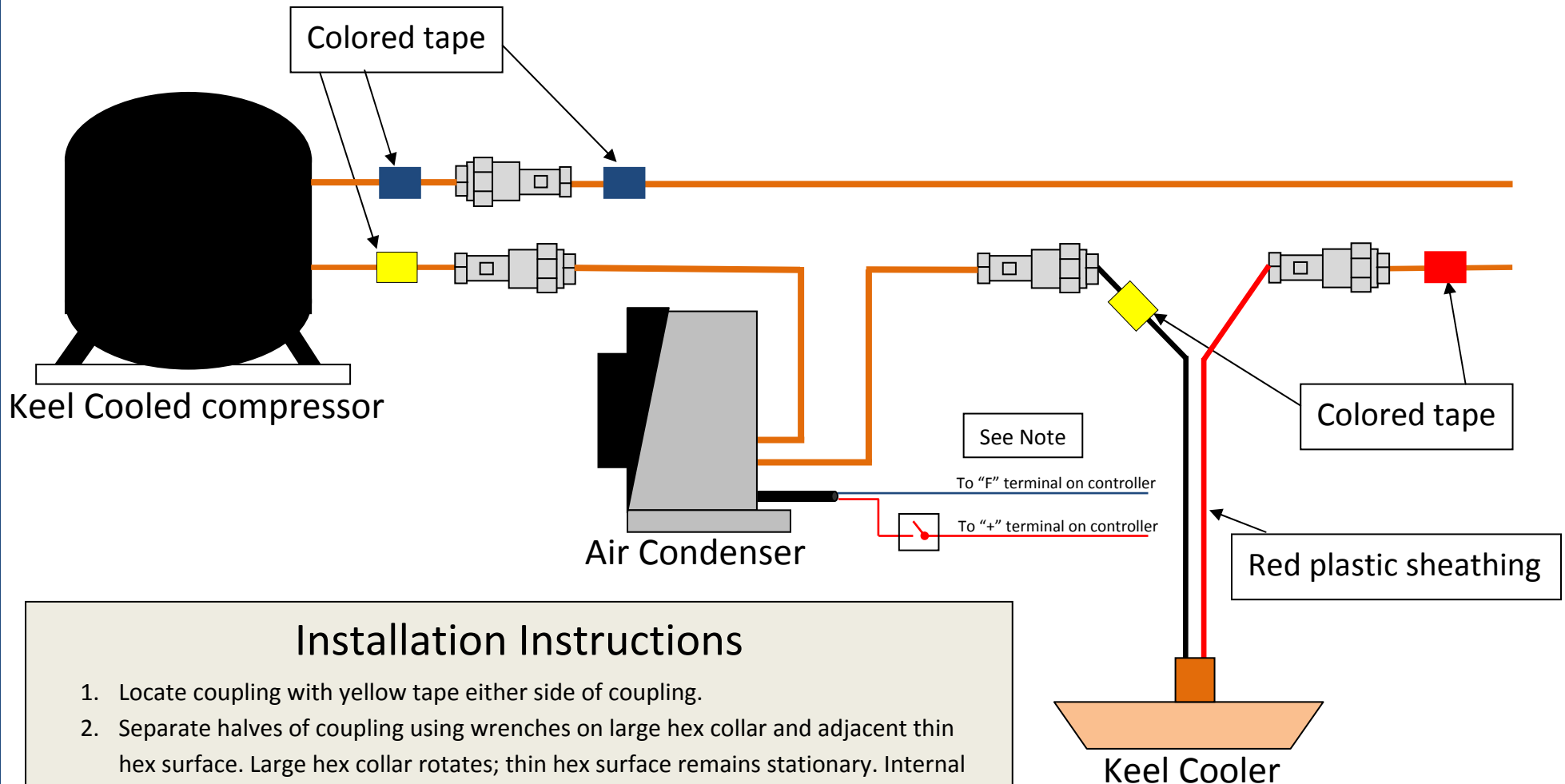

## Installation Instructions

1. Locate coupling with yellow tape either side of coupling.
2. Separate halves of coupling using wrenches on large hex collar and adjacent thin hex surface. Large hex collar rotates; thin hex surface remains stationary. Internal valves seal when coupling is separated. Protect exposed parts from dust, dirt, etc.
3. Remove dust caps from Air Condenser and connect to male and female halves of separated coupling. Ensure o-rings are not snagged or damaged. Do not use any lubricant, tape, etc. on the threads or rubber o-ring.
4. Make up connections as far as possible by hand, and then with wrenches until threads are covered. Do not over-tighten. The connection needs to be snug only, as the o-ring makes the seal and the threads then open the internal valves.

### **NOTES:**

- 1) Install on/off switch in red wire.
- 2) If compressor has an auxiliary fan, connect wires from Air Condenser in parallel.
- 3) Use fan only if boat is hauled or beached and Keel Cooler is not submerged.