



Refrigerators - Remote Compressor



C42



C75



C130

(See also "Undercounter" spec sheet)

Freezers - Remote Compressor



C30BT



C35BT



C55BT



C110BT

Specifications

		<u>C42</u>	<u>C75</u>	<u>C130</u>	<u>C30BT</u>	<u>C35BT</u>	<u>C55BT</u>	<u>C110BT</u>
Volume	Total (Cu Ft)	1.4	2.6	4.7				
	Freezer only	0.1	0.4	0.6	1.1	1.2	2	3.8
Freezer section	Height (Inches)	2.8	4.1	4.7				
	Width (Inches)	9.7	15.4	16.5				
	Depth (Inches)	8.3	9.8	13.4				
Weight	Lbs	27.5	46.7	62.6	48.5	41.9	60	78
Power Supply	12v/24v DC	Standard	Standard	Standard	Standard	Standard	Standard	Standard
	12v/24v Dc plus 110v/230v AC	Optional	Optional	Optional	Optional	Optional	Optional	Optional
12/24v DC	Nominal input (W)	31	40	43	38	38	38	52
	Current consumption (Amps) 12/24v	2.6/1.3	3.4/1.7	3.8/1.9	3.4/1.7	3.4/1.7	3.2/1.6	4.4/2/2
110/230v AC	Nominal input (W)	31	40	43	38	38	38	52
	Current consumption (Amps) 115/230v	0.4/0.2	0.5/0.25	0.6/0.3	0.5/0.25	0.5/0.25	0.5/0.25	0.6/0.3
Features	Interchangeable door opening	Yes	Yes	Yes	Yes	Yes	Yes	Yes
	Magnetic closure	Yes	Yes	Yes	Yes	Yes	Yes	Yes
	Internal light	No	Yes	yes	No	No	No	No
Trim finish - Door	Black - Interchangeable panel	Yes	Yes	Yes	Yes	Yes	Yes	Yes
	Stainless steel	Optional	Optional	Optional	N/A	N/A	Optional	Optional
Mounting options	Flush flange	Yes	Yes	Yes	Yes	Yes	Yes	Yes
	Surface flange	Optional	N/A	N/A	N/A	Optional	N/A	N/A
	Tubing length to compressor (ft)	5	5	5	5	5	5	5

Details may not be exactly as shown. Contact Coastal to confirm details.

Dimensional data over:

Refrigerators - Remote Compressor

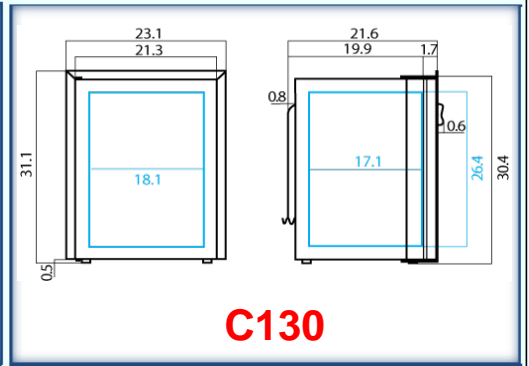
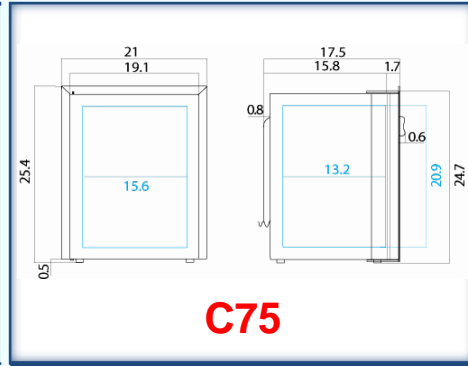
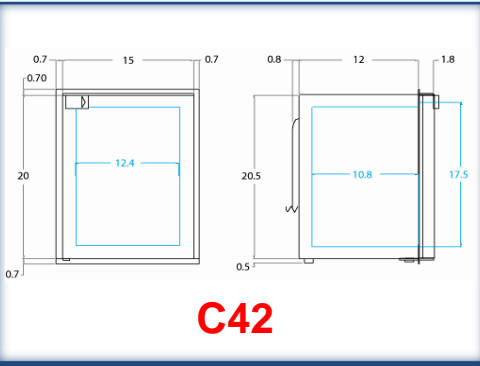

Freezers - Remote Compressor

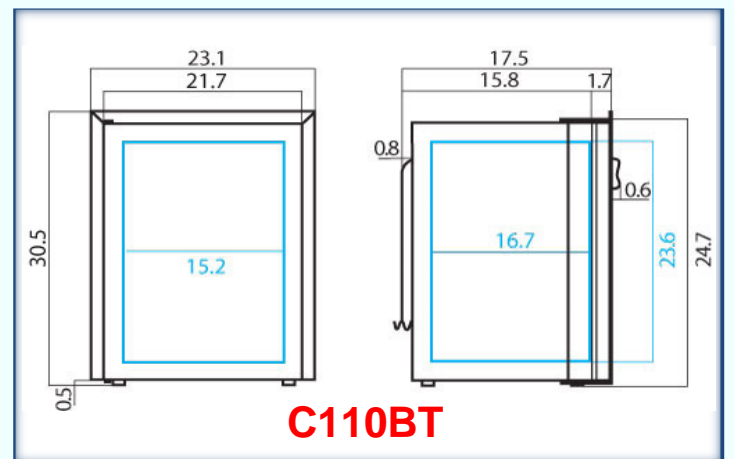
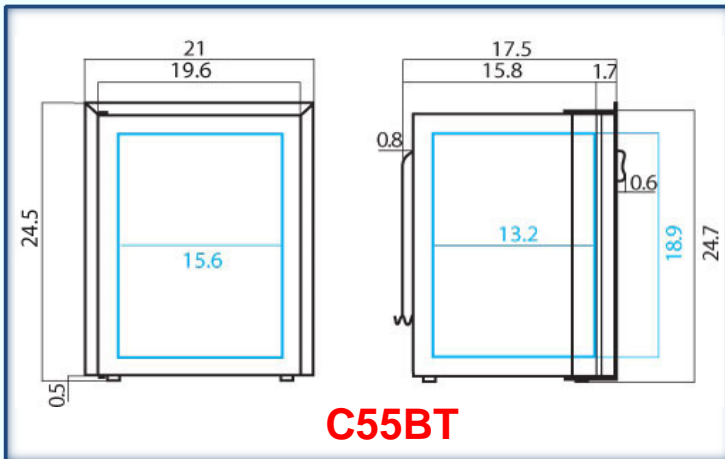
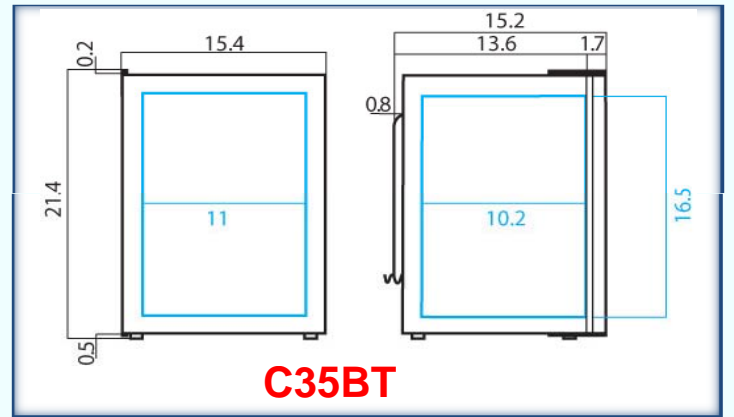
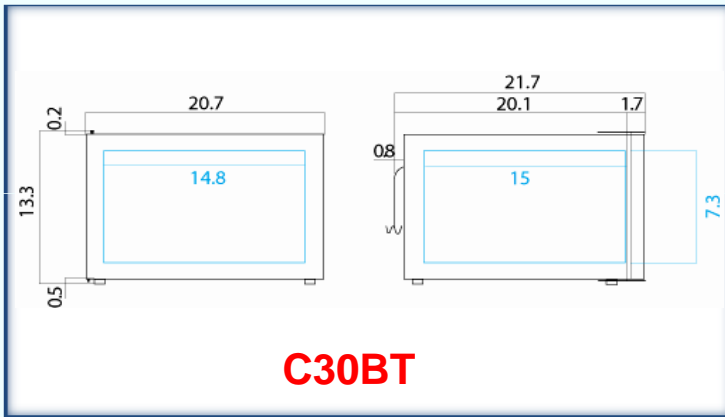

Coastal Climate Control, Inc.

4831 Telsa Drive - Suite H, Bowie MD 20715

www.vfsales.net www.CoastalClimateControl.com

Ph. 301-352-5738 info@vfsales.net