

Installation Instructions

1. Locate coupling at end of smaller tube from evaporator.
2. Separate halves of coupling using wrenches on large hex collar and adjacent thin hex surface. Large hex collar rotates; thin hex surface remains stationary. Internal valves should seal when coupling is separated. Protect exposed parts from dirt.
3. Without delay, remove dust caps from Filter/Drier and connect unit to male and female halves of separated coupling. Ensure o-rings are not snagged or damaged. Do not use any lubricant, tape, etc. on the threads or rubber o-ring.
4. Make up connections as far as possible by hand, and then with wrenches until threads are covered. Do not over-tighten. The connection needs to be snug only, as the o-ring makes the seal and the threads then open the internal valves.
5. IMPORTANT – Position the assembly as shown below and secure as best as possible.

Evaporator
Flat, Bin, Horizontal,
or MS cabinet

Single Tube

Filter/Drier must be positioned
vertically with arrow pointing down

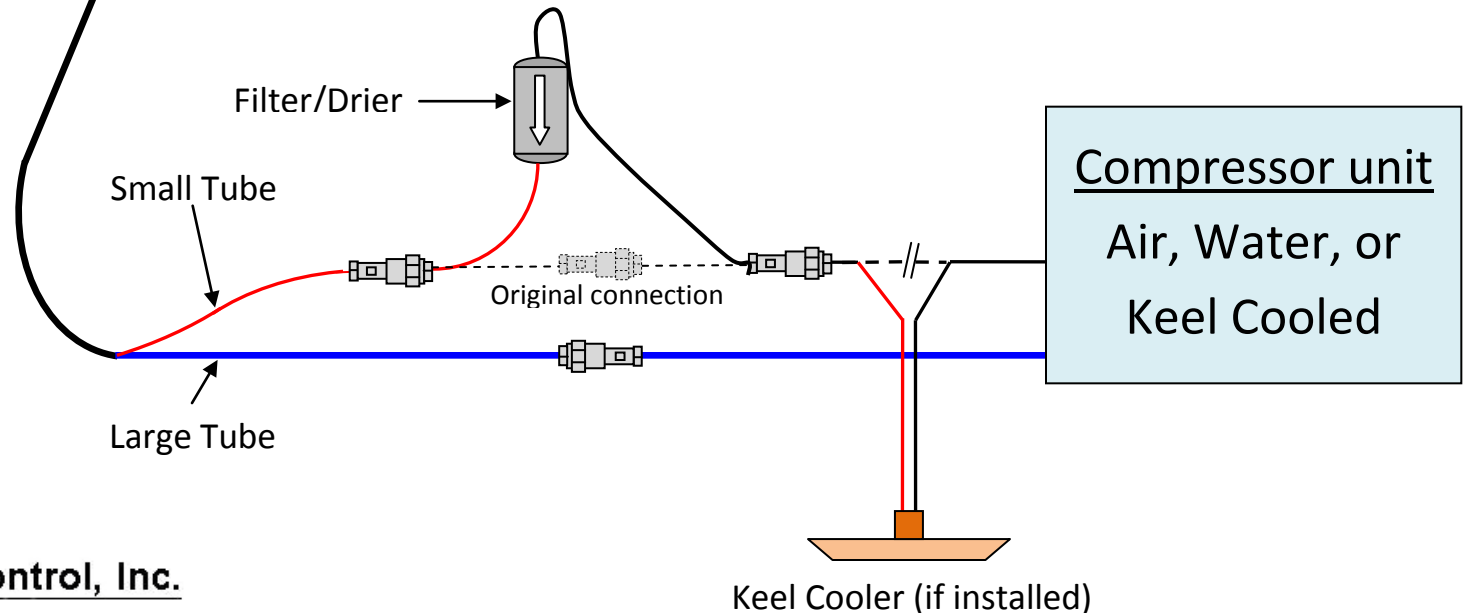

Coastal Climate Control, Inc.

301-352-5738 info@coastalclimatecontrol.com

Version 3.1 RW 10.27.14